

DH4–B980

Electronic Eyelet Button Holer



Specifications

Specifications	DH4–B980–00	DH4–B980–01	DH4–B980–02
Main use	Men's clothes and ladies' clothes		Jeans and work clothes
Sewing speed	1,000–2,000 rpm (100-rpm steps)		
Buttonhole length	10 – 50mm	10 – 38 mm	L1: 14 – 18 mm L5: 28 – 32 mm L2: 18 – 22 mm L6: 32 – 36 mm L3: 22 – 26 mm L7: 36 – 40 mm L4: 26 – 30 mm
Stitch length	0.5 – 2.0 mm (0.1 mm steps)		
Stitch width	1.5 – 3.2 mm		
Tacking length	0 mm, 3 – 43 mm (1 mm steps)		
Cloth presser height	12 mm		16 mm
Stitch shape changing	Selected by a program		
Cut timing selection	Selected by a switch		
Starting method	Dual switch (cloth presser switch and start switch) or single switch		
Feed method	Intermittent feed by three pulse motors (X, Y, θ)		
Needle	DO × 558 #80 – #120 (Schumetz)		
Safety equipment	Built-in emergency stop function and automatic stopping device which stops the machine when the safety circuit is activated.		
Air pressure	Main regulator: 0.49 Mpa Knife pressure regulator: 0.3 Mpa		
Air consumption	43.2 l / min (8 cycle / min)		
Noise level	81 dB at max. speed of 2,000 rpm, measured according to ISO 10821		
Dimensions	1,200 mm (W) × 590 mm (D) × 1,120 mm (H)		
Work table legs	T-shaped height-adjustable type		
Power supply	Single-phase 110, 200, 220, 230, 240 V Three phase 220, 380, 415 V Max. electric power consumption: 1kVA		
Weight	175 kg		

Device for each sub-class

DH4- B980-



		Upper thread trimmer	Lower thread trimmer		Upper thread nipper*2	Fly indexer	Upper gimp guide	Circular stitching buttonhole set	Round bar tacking set
			Long	Short					
00	Standard bar tacking / eyelet buttonhole with taper bar	○	–	–	Option*2	–	Option*2	Option	Option
01		○	○	–	Option*2	–	Option*2	Option	Option
02		○	–	○*1	Option	Option	–	–	–
03		○	–	–	○	–	–	–	–
04		○	○	–	○	–	–	–	–
05		○	–	○*1	○	Option	–	–	–
12	Straight bar tacking	○	–	○*1	Option	–	–	–	–
15		○	–	○*1	○	–	–	–	–
52	Eyelet button hole with taper bar (with fly indexer)	○	–	○*1	Option	○	–	–	–
55		○	–	○*1	○	○	–	–	–

*1 If using the lower thread trimmer (short type), please specify the buttonhole length when ordering.

There is 10 mm of difference in the knife installation positions between L1 – L4 and L5 – L7.

*2 The upper thread nipper cannot be used in conjunction with the upper gimp guide.

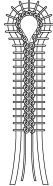
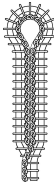
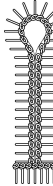
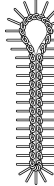
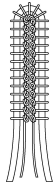
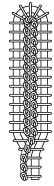
Sewing shape

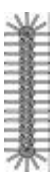
Eyelet buttonhole				Straight buttonhole			
Eyelet buttonhole	Eyelet Buttonhole with taper	With straight bar tack	With round bar tack	Straight buttonhole	Straight buttonhole with taper	With straight bar tack	With round bar tack
							

Round bar tacker set

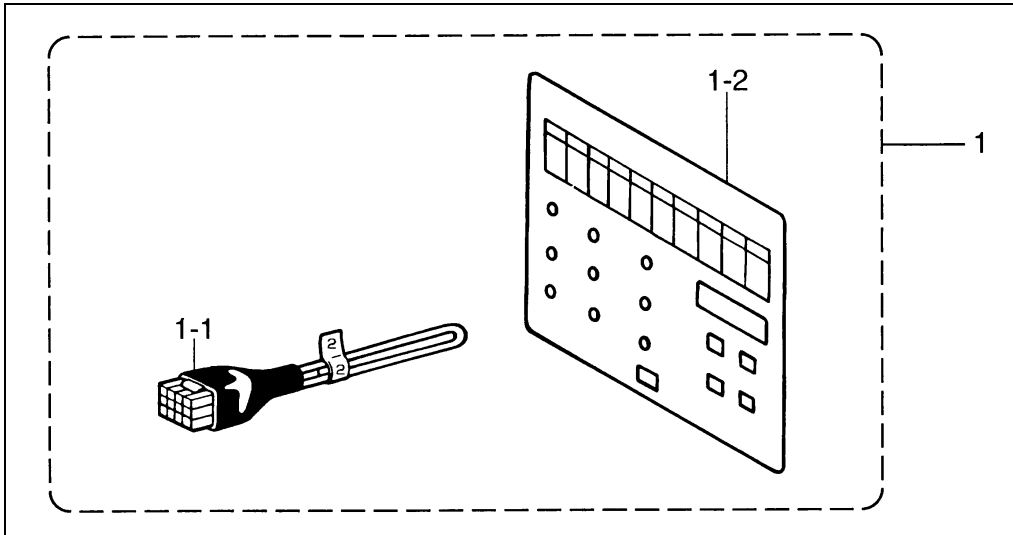

Ref. No.	Part name	Part code	
1	Round bar tacker set	S45195-000	
1-1	Harness	S44954-000	
1-2	Panel sheet	S44953-000	
Pressers	Buttonhole length	Pressers	Buttonhole length
L1	16 – 19 mm	L5	30 – 33 mm
L2	20 – 23 mm	L6	34 – 37 mm
L3	24 – 27 mm	L7	38 – 41 mm
L4	28 – 31 mm		

*When a short thread trimmer is attached, each presser is designated as L1–L4 according to the stitch length. Use the appropriate presser as per the table above.

Circular stitching set

Sewing shape	Outer diameter of circular stitching	Presser harness
	-10 mm	-
	-12 mm	Presser harness D13 S41506-000

Exchange parts set

For - 00

Stitching diameter (mm)	Parts set	Contents
2	Exchange parts set D2 (-00) S42174-001	Cloth presser set D11 (-00) S43934-001
		Knife (D2) S41346-001
		Hammer (D3) S41344-001
3	Exchange parts set D3 (-00) S41998-001	Cloth presser set D11 (-00) S43934-001
		Knife (D3) S41347-001
		Hammer (D3) S41344-001
4	Exchange parts set D4 (-00) S42175-001	Cloth presser set D13 (-00) S43935-001
		Knife (D4) S41348-001
		Hammer (D5) S41345-001
5	Exchange parts set D5 (-00) S41999-001	Cloth presser set D13 (-00) S43935-001
		Knife (D5) S41349-001
		Hammer (D5) S41345-001

For - 01

Stitching diameter (mm)	Parts set	Contents
2	Exchange parts set D2 (-01) S42176-001	Cloth presser set D11 (-01) S43936-001
		Knife (D2) S41346-001
		Hammer (D3) S41344-001
3	Exchange parts set D3 (-01) S42000-001	Cloth presser set D11 (-01) S43936-001
		Knife (D3) S41347-001
		Hammer (D3) S41344-001
4	Exchange parts set D4 (-01) S42177-001	Cloth presser set D13 (-01) S43937-001
		Knife (D4) S41348-001
		Hammer (D5) S41345-001
5	Exchange parts set D5 (-01) S42001-001	Cloth presser set D13 (-01) S43937-001
		Knife (D5) S41349-001
		Hammer (D5) S41345-001

(For -02) Parts for changing buttonhole length

Parts set	Contents
< L1 14 – 18 mm >	
Exchange parts set (L1) S38572-001	(L1) plate (R) assy S38576-101
	(L1) plate (L) assy S38577-101
	Harness (L1) S37869-000
	Hammer (S12) S37702-001
	Hammer (S16) S37704-001
< L2 18 – 22 mm >	
Exchange parts set (L2) S38573-001	(L2) plate (R) assy S38578-101
	(L2) plate (L) assy S38579-101
	Harness (L2) S37871-000
	Hammer (S16) S37704-001
	Hammer (S20) S37706-001
< L3 22 – 26 mm >	
Exchange parts set (L3) S38574-001	(L3) plate (R) assy S38580-101
	(L3) plate (L) assy S38581-101
	Harness (L3) S37871-000
	Hammer (S20) S37706-001
	Hammer (S24) S37708-001
< L4 26 – 30 mm >	
Exchange parts set (L4) S38575-001	(L4) plate (R) assy S38582-101
	(L4) plate (L) assy S38583-101
	Harness (L4) S37873-000
	Hammer (S24) S37708-001
	Hammer (S26) S37709-001
< L5 28 – 32 mm >	
Exchange parts set (L5) S41467-001	(L5) plate (R) assy S41470-101
	(L5) plate (L) assy S41471-101
	Harness (L5) S41476-000
	Hammer (26) S37197-001
	Hammer (30) S37199-001

(For -02) Parts for changing buttonhole length

Parts set	Contents
< L6 32 – 36 mm >	
Exchange parts set (L6) S41468-001	(L6) plate (R) assy S41472-101
	(L6) plate (L) assy S41473-101
	Harness (L6) S41476-000
	Hammer (30) S37199-001
	Hammer (34) S37201-001
< L7 36 – 40 mm >	
Exchange parts set (L7) S41469-001	(L7) plate (R) assy S41474-101
	(L7) plate (L) assy S41475-101
	Harness (L7) S41478-000
	Hammer (34) S37201-001
	Hammer (38) S35093-001

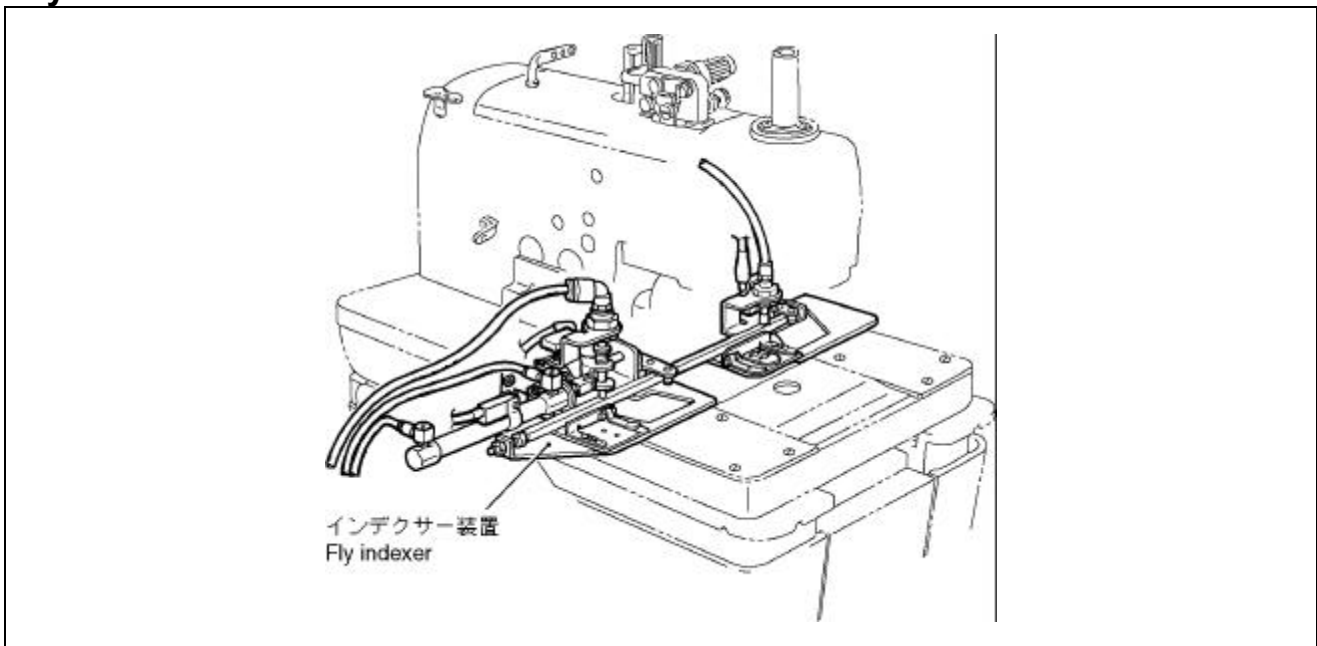

Specifications

	Standard size	Large size
Applicable specifications	L1 (Buttonhole length : 14 - 18 mm), L2 (Buttonhole length : 18 - 22 mm), L3 (Buttonhole length : 22 - 26 mm), L4 (Buttonhole length : 26 - 30 mm)	L5 (Buttonhole length : 28 - 32 mm), L6 (Buttonhole length : 32 - 36 mm), L7 (Buttonhole length : 36 - 40 mm)
Distance between button holes	38.1 mm, 50.8 mm, 44.45 mm	38.1 mm, 50.8 mm, 44.45 mm, 57.15 mm
No. of buttonholes	1 - 4 holes	1 - 6 holes
Horizontal sewing margin	(L1 - L4) 9 - 21 mm, (L5 - L7) 9 - 11 mm	
Vertical sewing margin	30 - 40 mm	
Max. horizontal feed amount	152.4 mm	285.75 mm

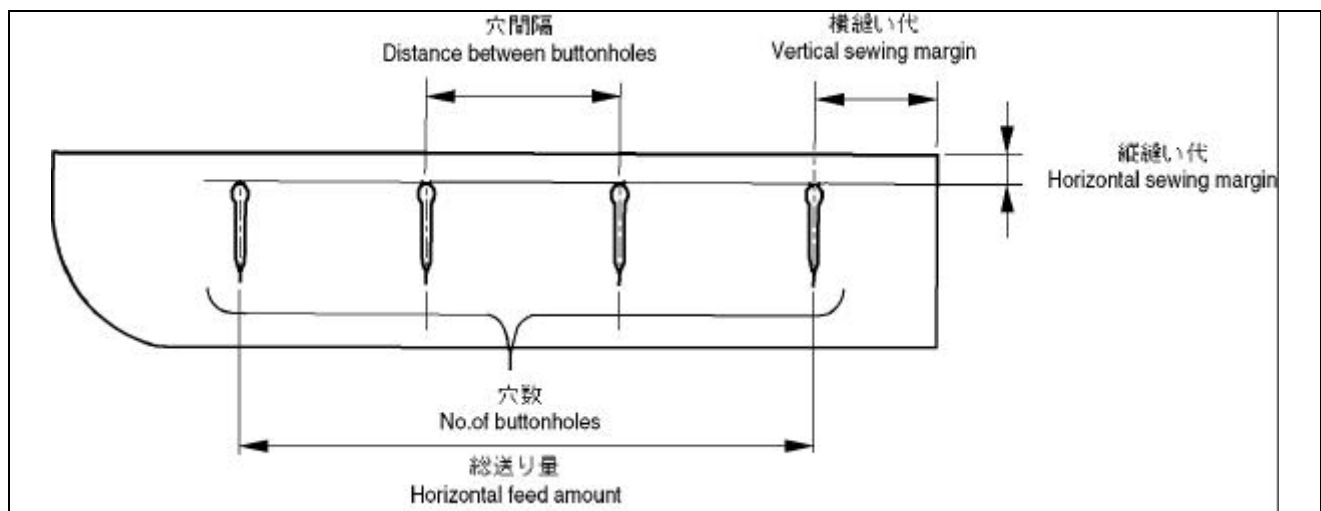

From the library of: Diamond Needle Corp

Parts for the standard-sized fly indexer (Conventional parts)

Part name	Part code	Applicable specifications	Remarks
Fly indexer assy	S42168-101	For L1, L2, L5	Without upper thread nipper
	S42169-101		With upper thread nipper
	S42110-101	For L3, L4, L6, L7	Without upper thread nipper
	S42170-101		With upper thread nipper

*If the standard-sized fly indexer is used for sewing with a non-standard distance between buttonholes and a non-standard number of buttonholes (up to 9), you need to make additional holes in the cloth feed bar (F) assy (optional part). For this processing, refer to the instruction manual supplied with this optional part.

Part name	Part code	Applicable specifications
Cloth feed bar (F) assy (L1, L2)	S45193-001	L1, L2, L5
Cloth feed bar (F) assy (L3, L4)	S45194-001	L3, L4, L6, L7

Parts for the large-sized fly indexer

Part name	Part code	Applicable specifications	Remarks
Fly indexer (LS) assy	S48329-001	L1, L2, L5	Without upper thread nipper
Fly indexer (LL) assy	S48334-001	L3, L4, L6, L7	

*There are only four types of the distances between buttonholes for large-sized fly indexer.

Option parts
Upper thread nipper

[Models B980]

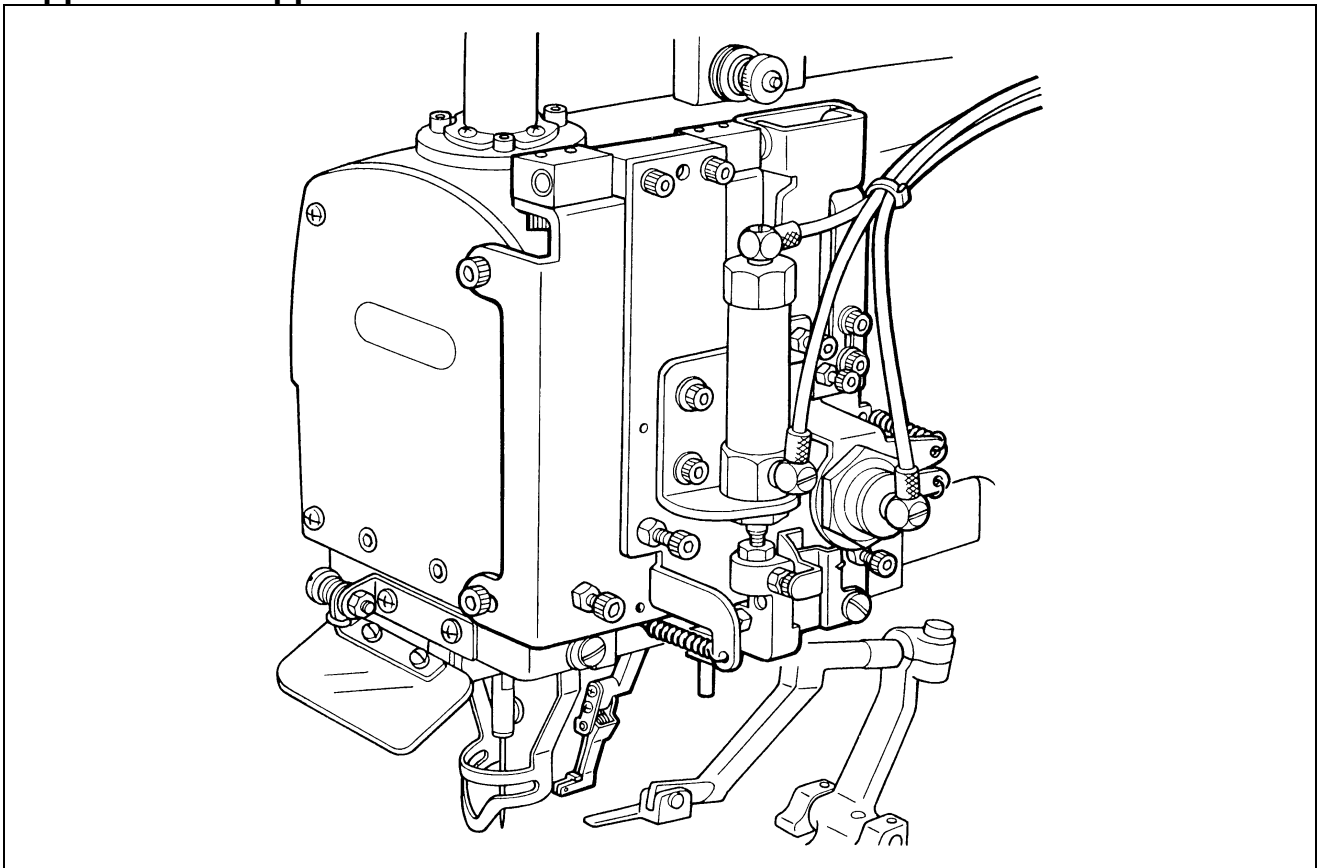

Part name	Part code	Q'ty
Thread nipper device set	S43406-001	1

Option parts
Gimp device

[Models B980]

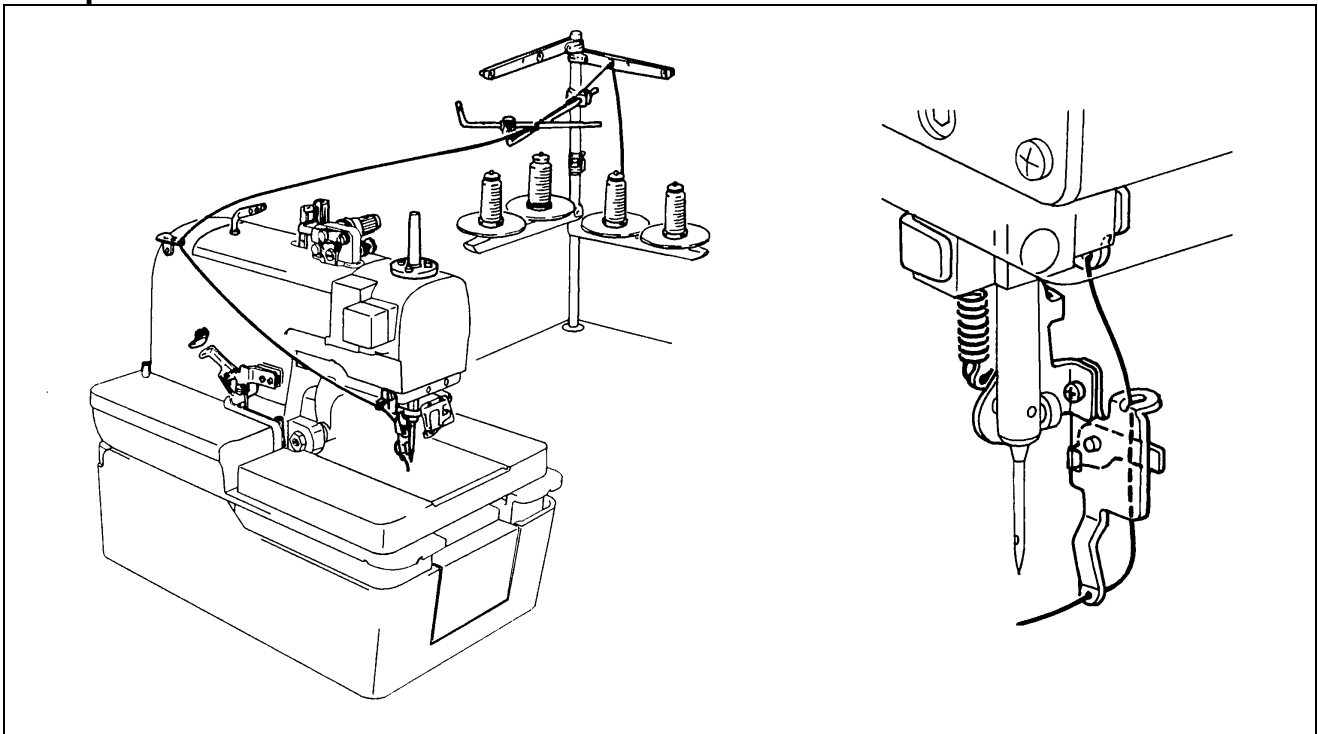

Parts set	Contents
Upper gimp guide set S42656-001	Upper gimp guide set S44503-001
	Cotton stand assy, 4DTHF S29854-109

From the library of: Diamond Needle Corp

Option parts
Hand start switch

[Models B980]

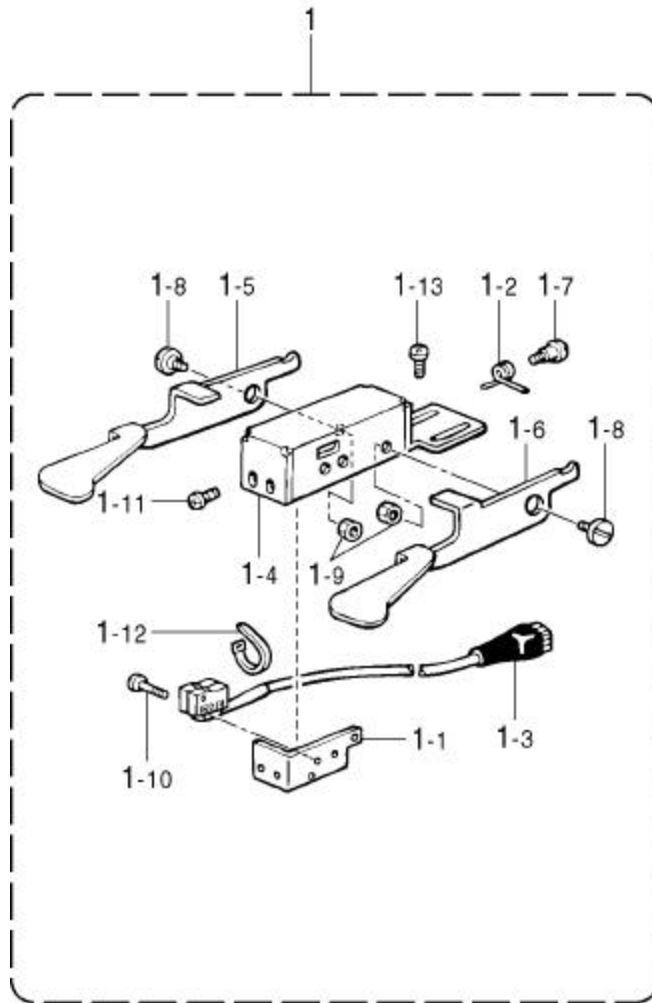

Ref. No.	Part name	Part code	Q'ty
1	Hand start switch assy	S39909-001	1
1-1	Switch set plate	S39913-001	1
1-2	Switch lever spring	S39914-001	1
1-3	Hand switch	S39915-000	1
1-4	Switch cover	S39910-001	1
1-5	Switch lever (L)	S39911-001	1
1-6	Switch lever (R)	S39912-001	1
1-7	Stud screw, M4	S34922-101	1
1-8	Stud screw, M4	S34966-001	2
1-9	Nut, 2M4	012400-202	3
1-10	Screw, M2.38	146124-001	2
1-11	Screw, bind M3 x 6	060300-616	2
1-12	Band PLTIM	S04557-000	1
1-13	Screw, bind M4 x 8	060400-816	2

Option parts
Cloth guide

[Models B980]

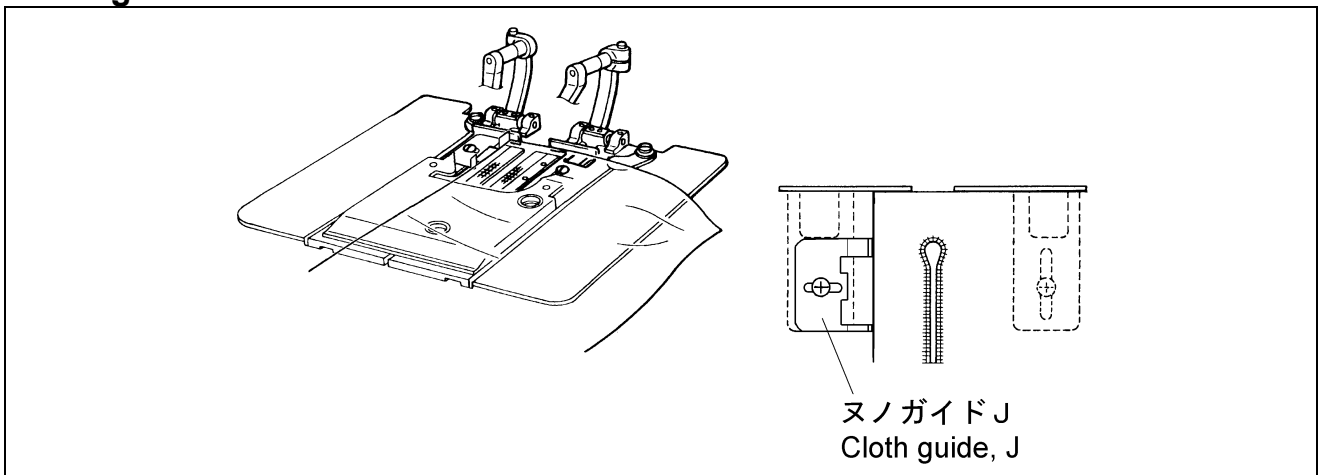

Part name	Part code	Q'ty
Cloth guide, J	S37870-000	1

Movable knife cover

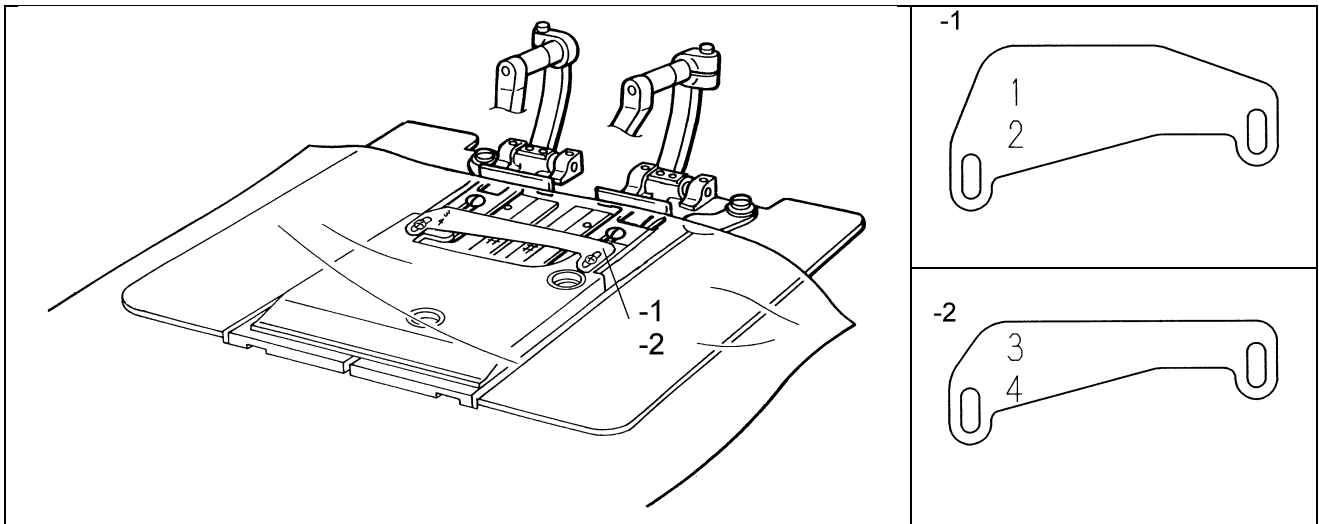

Ref. No.	Part name	Part code	Q'ty
	<L1, L2, L5, L6>		
1	Movable knife cover, L1-2	S37698-000	1
	<L3, L4, L7>		
2	Movable knife cover, L3-4	S37699-000	1

Gauge parts list
(For -00, -01, -02) Cloth presser

[Models B980]

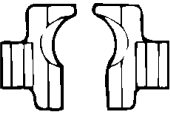
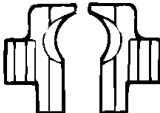
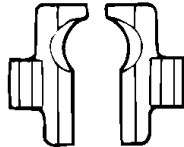
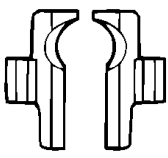
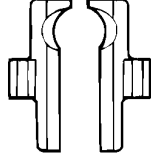
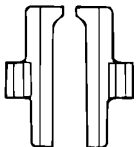
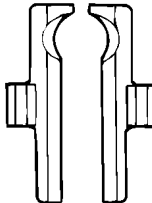
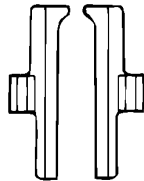
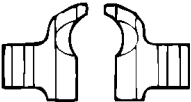
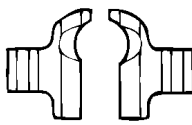
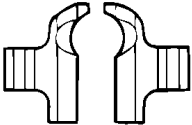
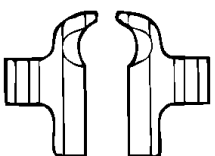
L	S35455-001	S39929-001	S35197-001	S39931-001
R	S35454-001	S39930-001	S35198-001	S39932-001
	<10 – 18 mm>	<18 – 22 mm>	<22 – 26 mm>	<26 – 30 mm>
				
	S35453-001	S35200-101	S37679-001	S37677-101
	S35452-001	S35199-101	S37680-001	S37678-101
-00 & -01	<26 – 38 mm>	<38 mm>	<50 mm>	<50 mm>
				
L	S37755-001	S37689-001	S37691-001	S37759-001
R	S37754-001	S37690-001	S37692-001	S37758-001
	L1 <14 – 18 mm>	L2 <18 – 22 mm>	L3 <22 – 26 mm>	L4 <26 – 30 mm>
-02				

For circular stitching cloth presser

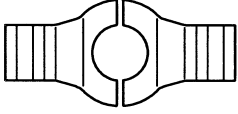
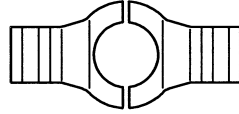
R & L	S41336-001	S41337-001
	D11 < – 10 mm>	D13 < – 12 mm>
-00 & -01		

For waist band cloth presser

Parts set	Contents
< L3 22 – 26 mm >	
Cloth presser (L3W) set S43701-000	Cloth presser (L-L3W) assy S43702-000
	Cloth presser (R-L3W) assy S43703-000
< L4 26 – 30 mm >	
Cloth presser (L4W) set S43704-000	Cloth presser (L-L4W) assy S43705-000
	Cloth presser (R-L4W) assy S43706-000

Gauge parts list

Needle plate

[Models B980]

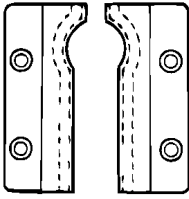
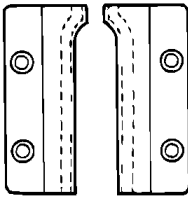
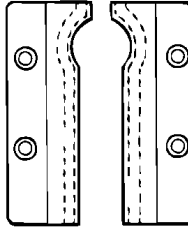
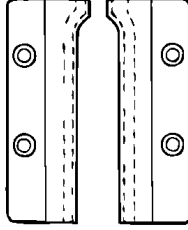
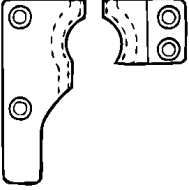
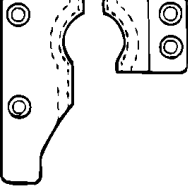
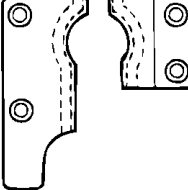
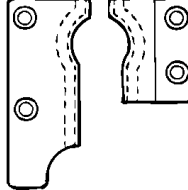
L	S35308-101 (L)	S35307-101 (SL)	S37683-101 (L-50)	S37681-101 (SL-50)
R	S35309-101 (R)	S35306-101 (SR)	S37684-101 (R-50)	S37682-101 (SR-50)
	<38 mm>	<38 mm>	<50 mm>	<50 mm>
-00 & -01				
L	S37643-101 (L1L)	S37645-101 (L2L)	S37647-101 (L3L)	S37649-101 (L4L)
R	S37644-101 (L1R)	S37646-101 (L2R)	S37648-101 (L3R)	S37650-101 (L4R)
	L1 <14 - 18 mm>	L2 <18 - 22 mm>	L3 <22 - 26 mm>	L4 <26 - 30mm>
-02				

For circular stitching cloth presser

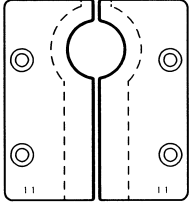
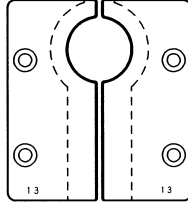
L	S41339-001	S41341-001
R	S41338-001	S41340-000
	D11 <- 10 mm>	D13 <- 12 mm>
-00 & -01		

Gauge parts list

Knife

[Models B980]

S35439-101 <38 mm>	S35437-101 <38 mm>	S35480-101 <38 mm>	S35482-101 <38 mm>	S35408-101 (S) <38 mm>
S35438-101 <50 mm>	S35436-101 <50 mm>	S35481-101 <50 mm>	S35483-101 <50 mm>	S35409-101 (S) <50 mm>

For circular stitching knife

S41346-001 <D2>	S41347-001 <D3>	S41348-001 <D4>	S41349-001 <D5>

Hammer

-00 & -01	Size (mm)	10	12	14	16
	Part code	S37211-001	S37210-001	S37209-001	S37208-001
	Size (mm)	18	20	22	24
	Part code	S37194-001	S35092-001	S37195-001	S37196-001
	Size (mm)	26	28	30	32
	Part code	S37197-001	S37198-001	S37199-001	S37200-001
-02	Size (mm)	34	36	38	50
	Part code	S37201-001	S37202-001	S35093-001	S35479-001
	Size (mm)	10	12	14	16
	Part code	S37701-001	S37702-001	S37703-001	S37704-001
	Size (mm)	18	20	22	24
	Part code	S37705-001	S37706-001	S37707-001	S37708-001
	Size (mm)	26			
	Part code	S37709-001			





For circular stitching hammer

-00 & -01	Size (mm)	phi 5 (D2, D3)	phi 7 (D4, D5)
	Part code	S41344-001	S41345-001

Gauge parts list

Double chain stitch looper mechanism

[Models B980]

	Eye Looper	Looper, R	Spreader, L	Spreader, R
Use				
Standard	S35411-001	S35410-001	S35413-101	S35412-101
For heavy	S35471-001		S35472-101	
For single chain stitch	S49078-001		S49079-001	

Throat plate

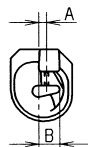
	Throat plate
Use	 
For -00 and -01	A = 1.8 mm B = 4.6 mm S47033-001
For -00 and -01 (For small hole)	A = 1.8 mm B = 4.6 mm S47034-001
For -02	A = 1.8 mm B = 4.6 mm S37752-001
For straight bar tack	A = ----- B = 4.6 mm S39923-101